

IDX1000/IDX1300 dry vacuum pump

From the pioneer in dry vacuum for industrial processes, the IDX1000/IDX1300 is the benchmark in performance for fast pumpdown of large chambers and high capacity pumping for industrial processes.

Based on the double-ended screw technology, the IDX dry vacuum pump will give you all the reliability and performance you want for your process. The IDX outperforms all other dry pumps in robustness, performance and ease of operation, giving you faster pump-down from atmosphere and managing higher throughput at low pressures. Dry pumping systems reduce energy costs, eliminate effluent and can give significant improvements in product quality, making them the ideal solution for many coating and metallurgy processes.



Features and benefits

- Improved performance and reliability
 - Continuous performance from atmosphere to ultimate
 - Excellent thermal profile and temperature control
 - Tolerates liquid and particles
 - Does not contaminate your process
- Cost efficient and environmentally friendly
 - Low power
 - No effluent generation
 - Dry running mechanism
- Designed for reliability and ease of maintenance
 - Flushable with water or solvent
 - Elimination of compression plate for better dust handling
 - Balanced rotor design
 - Standard accessory modules
 - Cooled and filtered oil
 - Double-ended design for improved thermal stability
- Sized to maximise pumpdown performance on modern large chambers
 - Even greater pump down speed from atmosphere to reach target pressures quickly
 - Bigger throughput capacity to deal with higher gas loads at low pressure
- Excellent liquid and dust handling
 - Self draining mechanism
 - No compression plate = Improved restart capability on dusty processes
- Routine maintenance on site, including oil filter change and bearings and seals
- Silencers are drainable and cleanable
 - Process lines are not disturbed
- No coating on rotors which wear away and result in drop in performance

Simple, rugged design

A rugged industrial mechanism for reliable, repeatable performance

- Double-ended design for better temperature control
- Minimal parts count
- Standard motors - ease of maintenance
- No rotor coatings - repeatable performance over the pump's life

Indirect cooling circuit

- Gives good thermal control, for improved reliability
- Enables use of poor quality cooling water
- Ensures even temperature distribution along the pump, eliminating hot and cold spots

Patented stator machining with integral head plate

- Improved tolerances gives better pumping efficiency
- No compression plate gives better dust and liquid handling

Pumped and filtered oil circuit

- Extended pump life
- Reduced wear

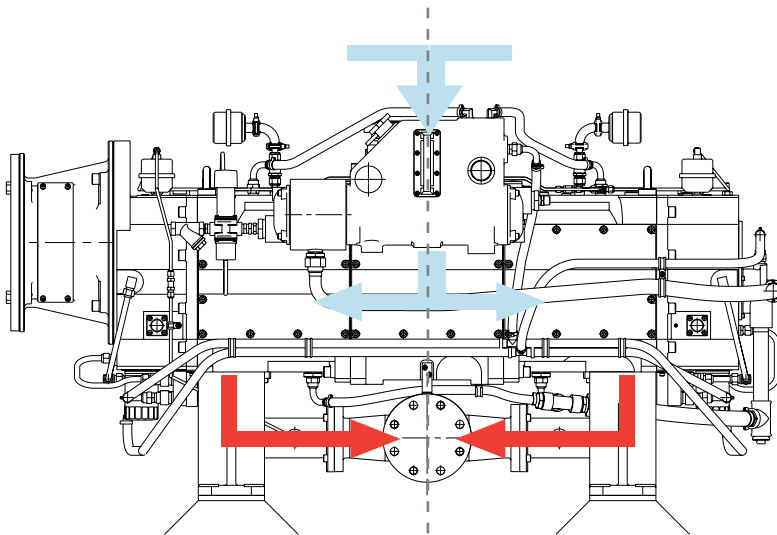

Compression in 2 smaller volumes

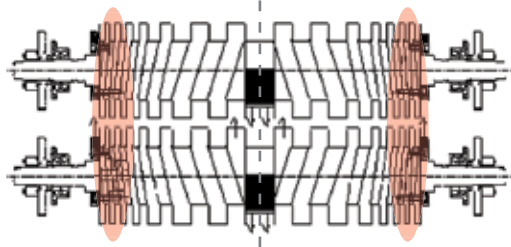

Less heat generated

*Closer tolerances
Tighter temperature control*

Systemisation tailored to match your process

The IDX is available in a range of standard packages with mechanical boosters to give capacities up to 30,000 m³/hr. These packages can be configured with exhausting booster stages to give very fast pump down duty.



Applications

- Metallurgy
 - Vacuum Induction Melting (VIM)
 - Vacuum Arc Refining (VAR)
 - Precision Investment Casting (PIC)
- Steel Degassing
 - Vacuum degassing (VD)
 - Vacuum Oxygen Degassing (VOD)
 - Ruhrstahl Heraeu (RH)
- Coating
 - Roll coating
 - Glass coating
- Component Drying
 - Transformers
 - Pipelines and cables
- Altitude and Space Chambers

Technical data

	Units	IDX1000	IDX1300
Mass			
50 Hz	kg (lb)	1560 (3439)	1590 (3506)
60 Hz	kg (lb)	1630 (3594)	1660 (3660)
Pumping speed			
Nominal	m ³ hr ⁻¹ (cfm)	1000 (589)	1300 (766)
Actual	m ³ hr ⁻¹ (cfm)	900 (560)	1250 (736)
Ultimate pressure	mbar (Torr)	5 x 10 ⁻² (3.75 x 10 ⁻²)	<5 x 10 ⁻² (3.75 x 10 ⁻²)
Noise	dB(A)	82	82
Motor	kW (hp)	30 (40) Optional - 22 (30)	30 (40)

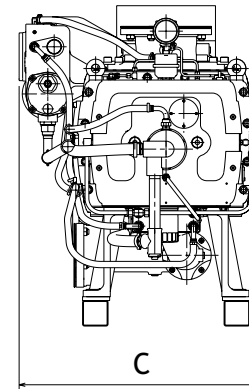
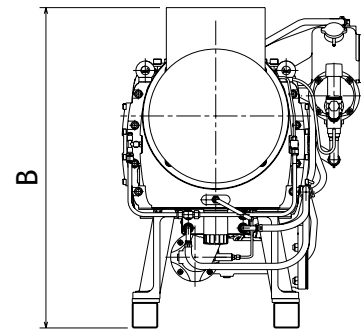
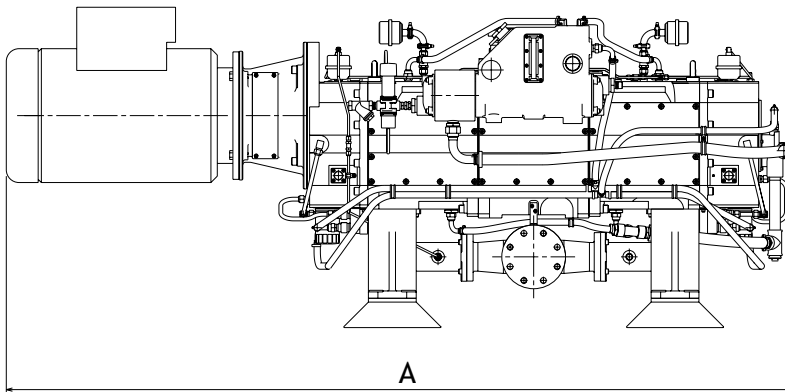

Dimensions - mm (inch)

Dimension	IDX1000	IDX1300
A	50 Hz 2250 (88.5)	2465 (97)
	60 Hz 2290 (90.1)	2515 (99)
B	854 (33.6)	1005 (39.6)
C	750 (29.5)	750 (29.5)

Performance

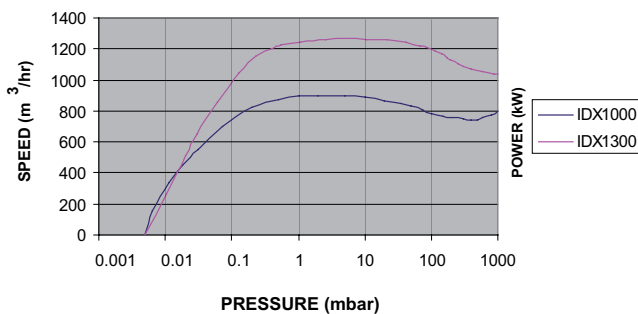

Global contacts

EUROPE

UK Crawley +44 1293 528844
 UK (local rate) 08459 212223
 Belgium Brussels +32 2 300 0730
 France Paris +33 1 4121 1256
 Germany Munich 0800 000 1456
 Italy Milan +39 02 48 4471

USA

Niagara (toll free) +1 800 848 9800
 BRAZIL
 Sao Paulo +55 11 3952 5000
 ISRAEL
 Qiryat-Gat +972 8 681 0633

ASIA PACIFIC

China (toll free) +86 400 111 9618
 India, Pune +91 20 4075 2222
 Japan, Yachiyo +81 47 458 8831
 Korea, Bundang +82 31 716 7070
 Singapore +65 6546 8408
 Taiwan R.O.C. Jhunan Town +886 3758 1000